



Nastro Curvo Rovescio Snodato

È usato principalmente per lo scarico di pezzi provenienti dai manipolatori o i robot che normalmente controllano l'avanzamento della tela passo a passo per permettere il raffreddamento dei pezzi.

È montato su ruote o su supporti fissi regolabili; È raccomandabile che il punto di deposito dei pezzi sia circondato con una protezione.

È consigliato l'uso di una tela supergrip, non solo per evitare che i pezzi scivolino, ma anche per facilitarne il raffreddamento.

Convoyeur Flexible Haut

Il est principalement utilisé pour le déchargement de pièces provenant des manipulateurs ou de robots qui souvenent contrôlent l'avance de la bande, pas à pas, pour permettre le refroidissement des pièces.

Il est monté sur roulettes, ou sur supports fixes réglables; il est recommandé que le point de dépôt de ces pièces soit entouré d'une protection.

Il est conseillé d'utiliser une bande à nid d'abeille, non seulement pour éviter que les pièces ne se déplacent, mais aussi pour faciliter le refroidissement.

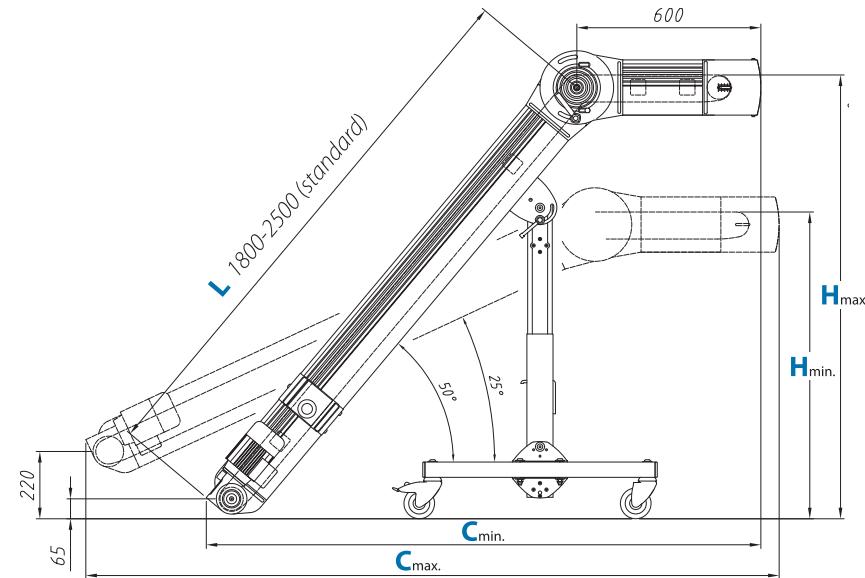
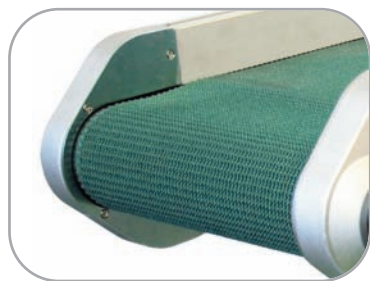

NCRS

Nastro Curvo Rovescio Snodato Convoyeur Flexible Haut Conveyor Articulated High

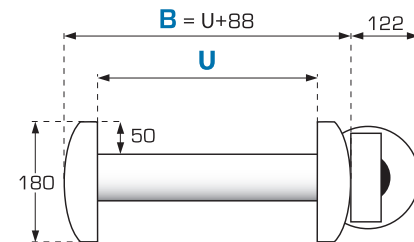

Conveyor Articulated High

mainly used to unload the pieces taken from Robot or manipulators. Progress is often controlled by the robot that makes advancing step by step to let cool down pieces deposited.

It's mounted on wheels, but also on feet adjustable, it is re-

commended that the point of deposit of the pieces is fenced by a guard.

It's recommended a belt Supergrip, to avoid that the pieces move, but also to facilitate the cooling.

AL-NCRS-1	U: 346	C: 1820/2270	H: 1000/1450
AL-NCRS-2	U: 446	C: 1820/2270	H: 1000/1450
AL-NCRS-3	U: 546	C: 1820/2270	H: 1000/1450
AL-NCRS-4	U: 646	C: 1820/2270	H: 1000/1450
AL-NCRS-5	U: 346	C: 2270/2900	H: 1300/1975
AL-NCRS-6	U: 446	C: 2270/2900	H: 1300/1975
AL-NCRS-7	U: 546	C: 2270/2900	H: 1300/1975
AL-NCRS-8	U: 646	C: 2270/2900	H: 1300/1975

AL-NCRS-S [speciale] Altre dimensioni su richiesta
Andere Abmessungen auf Anfrage - Other dimensions on request